

PUNCHES AND DIES FOR K-SERIES, SINGLE CYLINDER AND DUAL CYLINDER MODELS

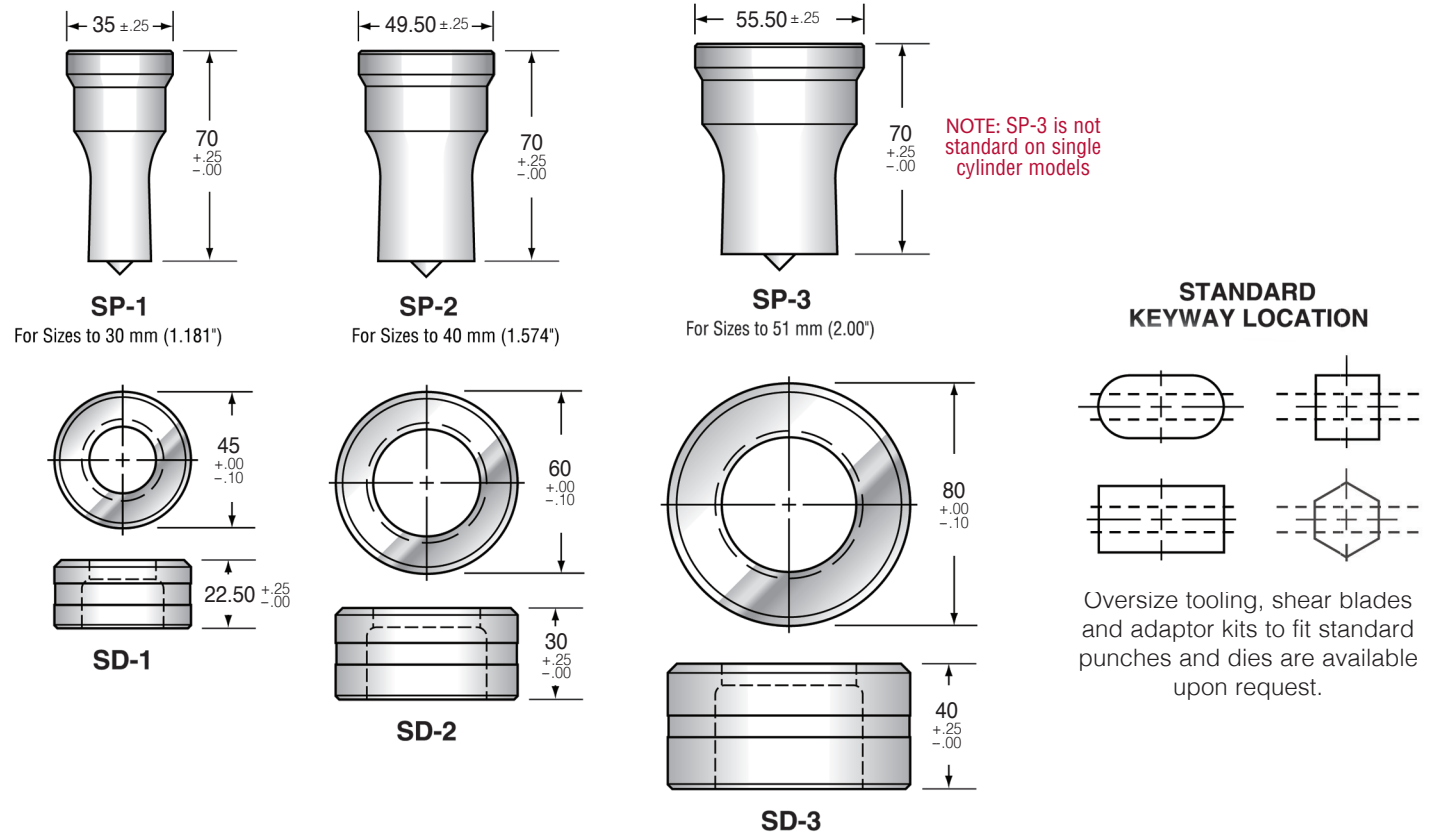

TOOLING FOR APS PLATE MACHINES

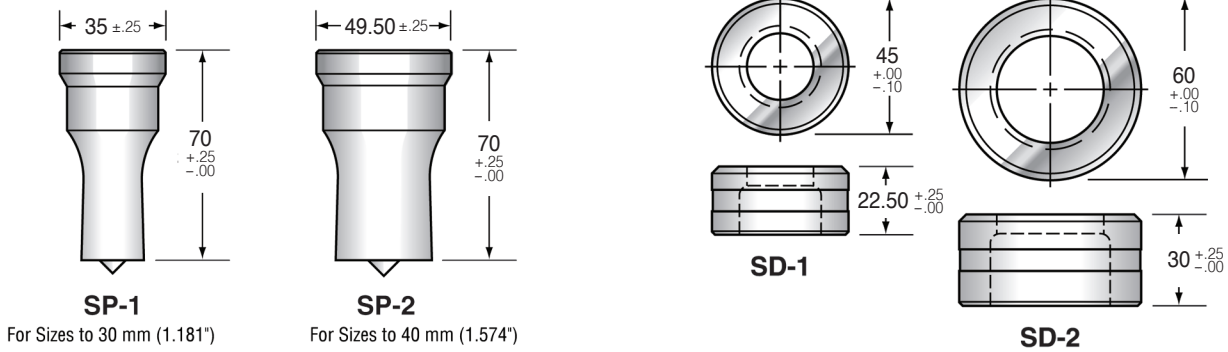

TOOLING FOR ALS ANGLE LINE MACHINES

